TECHNICAL MANUAL

OPERATOR'S AND ORGANIZATIONAL
MAINTENANCE MANUAL
CONTROL, RADIO SET C-6709/G
(NSN 5820-00-930-3597)

This copy is a reprint which includes current
pages from Change 1.

WARNING
RADIATION HAZARD

Electrical Surge Arrestors (ESAs), located in rfi filter box A6A1, on the back of the front panel, contain radioactive material. These arrestors are potentially hazardous when broken in large quantities. Consult qualified medical personnel and the Safety Director if you are exposed to broken arrestors. For first aid instructions, see TB 43-0116 and AR 755-15. Be extremely careful when replacing these arrestors and follow safe procedures in their handling, storage, and disposal.

Never place radioactive arrestors in your pocket. Be extremely careful not to break radioactive arrestors while handling them.

Never remove radioactive arrestors from containers until ready to use them.

Refer to TB 43-0116 and AR 755-15 for instructions on handling, storage, and disposal of radioactive material.

DON'T TAKE CHANCES!

WARNING

Adequate ventilation should be provided while using TRICHLOROTRIFLUOROETHANE. Prolonged breathing of vapor should be avoided. The solvent should not be used near heat or open flame; the products of decomposition are toxic and irritating. Since TRICHLOROTRIFLUOROETHANE dissolves natural oils, prolonged contact with skin should be avoided. When necessary, use gloves which the solvent cannot penetrate. If the solvent is taken internally, consult a physician immediately.

CHANGE)
)
NO. 1)

HEADQUARTERS
DEPARTMENT OF THE ARMY
Washington, DC, 21 June 1984

**Operator's and Organizational
Maintenance Manual
CONTROL,
RADIO SET C-6709/G
(NSN 5820-00-930-3597)**

TM 11-5820-615-12, 7 August 1979, is changed as follows:

1. New or revised material is indicated by a vertical bar in the margin of the page. Added or revised illustrations are indicated by a vertical bar in front of the figure caption.
2. Remove and insert pages as indicated below.

Remove

None
i and ii
1-1 through 1-3
2-1 through 2-4
None
A-1
B-1 and B-2
C-1 and C-2

Insert

A/(B blank)
i and ii
1-1 through 1-3 (1-4 blank)
2-1 through 2-4
2-4.1/(2-4.2 blank)
A-1/(A-2 blank)
B-1 and B-2
C-1 and C-2

3. File this change sheet in front of the publication.

By Order of the Secretary of the Army:

JOHN A. WICKHAM JR.
*General, United States Army
Chief of Staff*

Official:

ROBERT M. JOYCE
*Major General, United States Army
The Adjutant General*

DISTRIBUTION:

To be distributed in accordance with DA Form 12-51B, Operator's Maintenance requirements for C-6709.



5

SAFETY STEPS TO FOLLOW IF SOMEONE IS THE VICTIM OF ELECTRICAL SHOCK

1

DO NOT TRY TO PULL OR GRAB THE INDIVIDUAL

2

IF POSSIBLE, TURN OFF THE ELECTRICAL POWER

3

IF YOU CANNOT TURN OFF THE ELECTRICAL POWER, PULL, PUSH, OR LIFT THE PERSON TO SAFETY USING A WOODEN POLE OR A ROPE OR SOME OTHER INSULATING MATERIAL

4

SEND FOR HELP AS SOON AS POSSIBLE

5

AFTER THE INJURED PERSON IS FREE OF CONTACT WITH THE SOURCE OF ELECTRICAL SHOCK, MOVE THE PERSON A SHORT DISTANCE AWAY AND IMMEDIATELY START ARTIFICIAL RESUSCITATION

Change 1 A/(B blank)

**OPERATOR'S AND ORGANIZATIONAL MAINTENANCE MANUAL
FOR
CONTROL, RADIO SET C-6709/G
(NSN 5820-00-930-3597)
Basic manual is current as of April 1979
Change 1 is current as of 3 February 1984**

REPORTING ERRORS AND RECOMMENDING IMPROVEMENTS

You can help improve this manual. If you find any mistakes or if you know of a way to improve the procedures, please let us know. Mail your letter, DA Form 2028 (Recommended Changes to Publications and Blank Forms), or DA Form 2028-2 located in the back of this manual direct to: Commander, US Army Communications-Electronics Command and Fort Monmouth, ATTN: DRSEL-ME-MP, Fort Monmouth, New Jersey 07703. In either case, a reply will be furnished direct to you.

	<i>Paragraph</i>	<i>Page</i>
CHAPTER 1. INTRODUCTION		
Section I. Scope	1-1	1-1
Consolidated Index of Army Publication and Blank Forms	1-2	1-1
Maintenance Forms, Records, and Reports	1-3	1-1
Destruction of Army Electronics Materiel	1-4	1-1
Administrative Storage	1-5	1-1
Reporting Equipment Improvement Recommendations (EIR)	1-6	1-1
II. Description and Data		
Purpose and Use	1-7	1-1
Description	1-8	1-2
Tabulated Data	1-9	1-2
Major Components	1-10	1-3
Cable Requirements	1-11	1-3
CHAPTER 2. INSTALLATION INSTRUCTIONS		
Checking Unpacked Equipment	2-1	2-1
General Installation Instructions	2-2	2-1
Tools, Test Equipment, and Materials Required	2-3	2-1
Installation	2-4	2-3
Cable Connection	2-5	2-4
Interconnections	2-6	2-4
Preliminary Adjustments	2-7	2-5
Preliminary Checks	2-8	2-5
CHAPTER 3. OPERATING INSTRUCTIONS		
Section I. Operation Under Usual Conditions		
General	3-1	3-1
Operator/Crew Controls and Indicators	3-2	3-1
Preliminary Starting Procedure	3-3	3-2
Operating Procedures	3-4	3-2
Standby and Shutdown	3-5	3-3
II. Operation Under Unusual Conditions		
Operation Under Extreme Environmental Conditions	3-6	3-3
Operation Under Emergency Conditions	3-7	3-3
CHAPTER 4. OPERATOR/CREW MAINTENANCE INSTRUCTIONS		
Operator, Crew Tools and Equipment	4-1	4-1
Preventive Maintenance Checks and Services	4-2	4-1
Preventive Maintenance Checks and Services Periods	4-3	4-1

	<i>Paragraph</i>	<i>Page</i>
Cleaning	4-4	4-1
Troubleshooting	4-5	4-2
Maintenance of Control, Radio set C-6709/G	4-6	4-2
5. ORGANIZATIONAL MAINTENANCE INSTRUCTIONS		
Organizational Tools and Equipment	5-1	5-1
Repainting and Refinishing Instructions	5-2	5-1
Organizational Preventive Maintenance Checks and Services.....	5-3	5-1
Organizational Troubleshooting	5-4	5-1
Preparation for Storage	5-5	5-1
APPENDIX A. REFERENCES.....		A-1
APPENDIX B. COMPONENTS OF END ITEM LIST		
Section I. Introduction		B-1
II. Integral Components of End Item		B-2
III. Basic Issue Items		B-3
APPENDIX C. ADDITIONAL AUTHORIZATION LIST		
I. Introduction		C-1
II. Additional Authorization List		C-2
APPENDIX D. MAINTENANCE ALLOCATION		
Section I. Introduction		D-1
II. Maintenance Allocation Chart for Control, Radio Set C-6709/G		D-3
III. Tool and Test Equipment Requirements for Control, Radio Set C-6709/G.....		D-5
IV. Remarks		D-6
APPENDIX E. EXPENDABLE SUPPLIES AND MATERIALS LIST		
Section I. Introduction		E-1
II. Expendable Supplies and Materials List		E-2

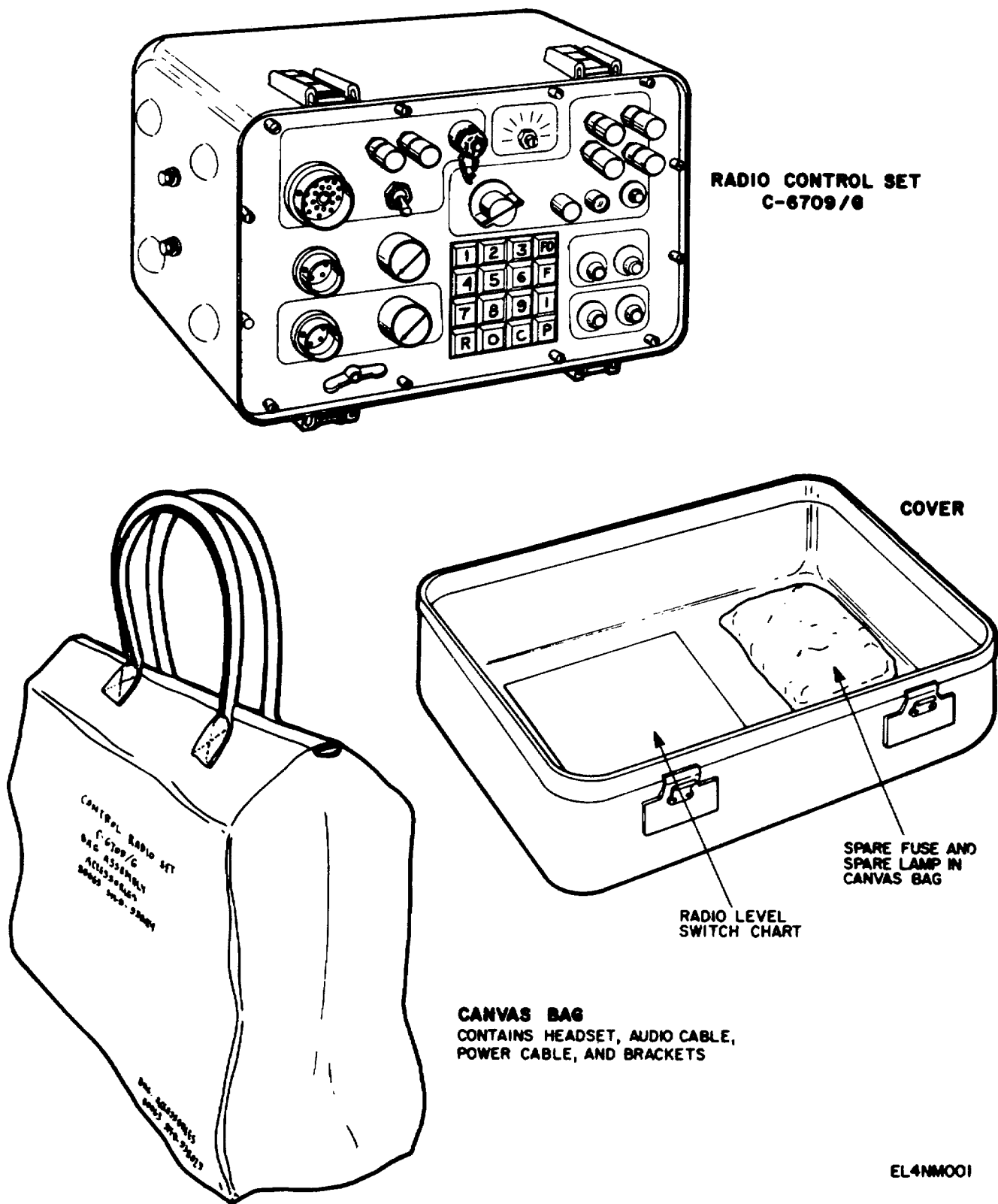

EL4NM001

Figure 1-1. Control, Radio Set C-6709/G.

CHAPTER 1 INTRODUCTION

Section I. GENERAL

1-1. Scope

This manual describes Control, Radio Set C-6709/G (fig. 1-1), and covers installation, operation, and maintenance. It includes instructions for all operational modes, and for operator and organizational maintenance.

1-2. Consolidated Index of Army Publications and Blank Forms

Refer to the latest issue of DA Pam 310-1 to determine whether there are new editions, changes or additional publications pertaining to the equipment.

1-3. Maintenance Forms, Records, and Reports

a. **Reports of Maintenance and Unsatisfactory Equipment.** Department of the Army forms and procedures used for equipment maintenance will be those prescribed by DA Pam 738-750, as contained in Maintenance Management Update.

b. **Reports of Packaging and Handling Deficiencies.** Fill out and forward SF 364 (Report of Discrepancy (ROD)) as prescribed in AR 735-11-2/DLAR 4140.55/NAVMATINST 4355.73A/AFR 400-54/MCO 4430.3F.

c. **Discrepancy in Shipment Report (DISREP) (SF 361).** Fill out and forward Discrepancy in Shipment Report (DISREP) (SF 361) as prescribed in AR 55-

38/NAVSUPINST 4610.33C/AFR 75-18/MCO P4610.19D/DLAR 4500.15.

1-4. Destruction of Army Electronics Material

Destruction of Army electronics materiel to prevent enemy use shall be in accordance with TM 750-244-2.

1-5. Administrative Storage

Administrative Storage of equipment issued to and used by Army activities will have preventive maintenance performed in accordance with the PMCS charts before storing. When removing the equipment from administrative storage the PMCS should be performed to assure operational readiness. Disassembly and repacking of equipment for shipment or limited storage are covered in paragraph 5-5.

1-6. Reporting Equipment Improvement Recommendations (EIR)

If your Control Radio Set C-6709/G needs improvement, let us know. Send us an EIR. You, the user, are the only one who can tell us what you don't like about your equipment. Let us know why you don't like the design. Put it on an SF 368 (Quality Deficiency Report). Mail it to Commander, US Army Communications-Electronics Command and Fort Monmouth, ATTN: DRSEL-ME-MP, Fort Monmouth, New Jersey 07703. We'll send you a reply.

Section II. DESCRIPTION AND DATA

1-7. Purpose and Use

a. The C-6709/G provides an interface between telephone (automatic or manual exchange) equipment

and any one of a number of different radio sets. The C-6709/G is used as a 4-wire termination with a 4-wire switchboard, and a radio set as shown in figure 1-2.

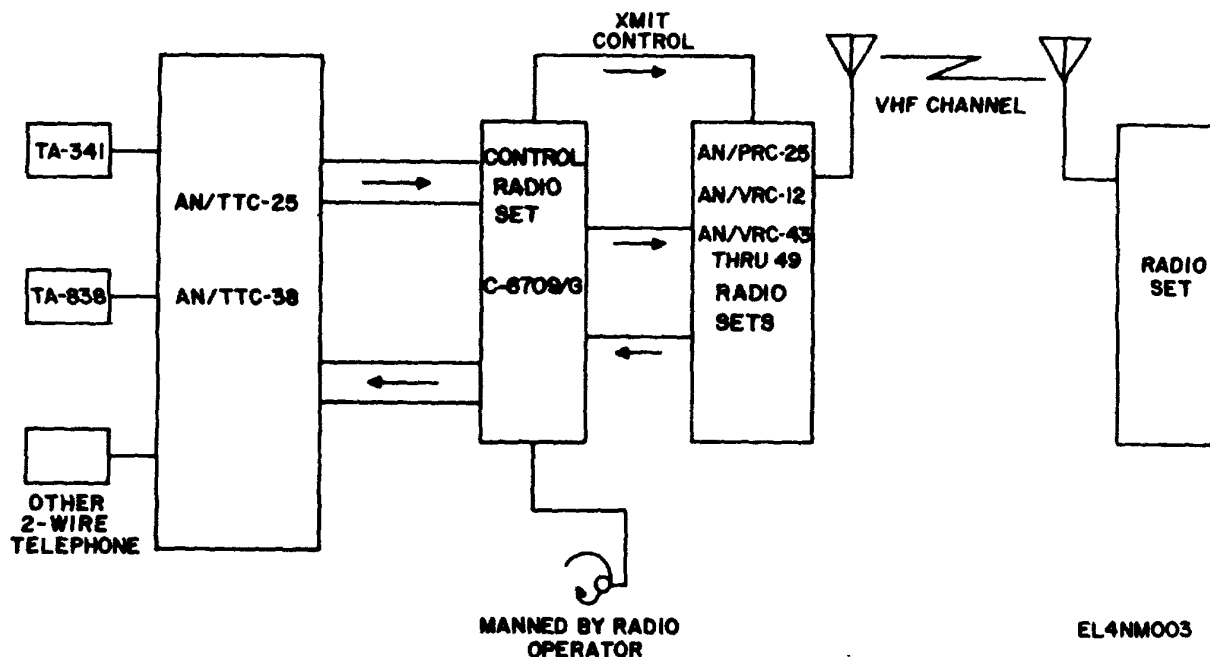

Figure 1-2. System Block Diagram.

b. The C-6709/G is a single, channel, solid-state radio-wire interface. The operator at the C-6709/G receives requests either from the radio link or the switchboard and establishes the interconnection. The C-6709/G can be used with automatic switchboards such as the AN/TTC-38V(*), and any of the following radio or crypto sets.

- | | |
|-------------------|------------|
| AN/URC-93V | AN/VRC-49 |
| AN/SRC-20A | ANPRC-104 |
| AN/SRC-21A | AN/MRC-138 |
| AN/ORC-106 | AN/GRC-193 |
| AN/PRC-70 | TSEC-KY-65 |
| AN/PRC-77 | TSEC-KY-38 |
| AN/VRC-12 | SEC-KY-57 |
| AN/VRC-43 through | |

1-8. Description

The C-6709/G is in a waterproof enclosure with a cover held by four latches. The cover has an air relief valve for equalizing air pressure before opening. All controls and interconnections are on the front panel, which is accessible when the cover is removed. The cover contains a small canvas bag to store a spare lamp and fuse. A separate canvas bag is used to store cables, headset, and two mounting brackets to mount the C-6709/G in a vehicle.

1-9. Tabulated Data

Circuit capacity	1 channel
Transmission line impedance	600 ohms
Transmission range (4 wire)	4 km (2.5 mi)
Frequency range	300 Hz to 70 kHz

Loop resistance (max)	675 ohms
Output level (SND)	0.3 Mvrms nominal
Input signal frequency	
Release	2600 Hz
Seize	2250 Hz
Acknowledge	570 Hz
Input signal levels	-30 dBm min.
Operating power	
Watts	3½ at 24 vdc
Volts	22 to 32 vdc (24 vdc nominal)
Operating temperature	-40 ° to +150 °F
Storage temperature	-70 ° to +160 °F
Relative humidity (up to 85 °F)	94 ± 4%
Operating altitude	Up to 15,000 ft above sea level
Storage altitude	Up to 40,000 ft above sea level
Converter output frequencies ± 1.3%:	
Release duration	2600 Hz (3-10 sec max)
Seize	2250 Hz
Acknowledge	570 Hz
Ringback	425 Hz (interrupted)
DTMF keysend signals:	
1	697 + 1209 Hz
2	697 + 1336 Hz
3	697 + 1477 Hz
FO	697 + 1633 Hz
4	770 + 1209 Hz
5	770 + 1336 Hz
6	770 + 1477 Hz
F	770 + 1633 Hz
7	852 + 1209 Hz
8	852 + 1336 Hz
9	852 + 1477 Hz
I	852 + 1633 Hz
R	941 + 1209 Hz
O	941 + 1336 Hz
C	941 + 1477 Hz
P	941 + 1633 Hz

1-10. Major Components

NSN	Item	Qty	Dimensions (in)			Wt (lb)
			Height	Depth	Width	
5820-00-930-3597	Control, Radio Set C-6709/G	1	9 1/8	9	12 1/2	17.0
	Canvas bag	1	9 1/2	5 3/4	14	0.4
5965-00-186-1194	Headset	1	-	-	-	0.4
5995-00-823-2834	Power Cable	1	-	108	-	0.9
	Audio Cable	2	-	120	-	0.3
	Mounting Bracket (LH) (Note 1)	1	8	2-5/8	3-3/4	0.7
	Mounting Bracket (RH) (Note 1)	1	8	2-5/8	3-3/4	0.7
	Mounting Bracket (Note 2)	2	3	1	3	0.3
	Instruction manual	1	11	1/2	8 1/2	1
	Spare fuse	1	-	-	-	Negligible
	Spare lamp	1	-	-	-	Negligible

NOTE 1. New brackets for mounting on horizontal surface.

NOTE 2. Used for older style brackets for attaching to vertical surfaces.

1-11. Cable Requirements

To connect the C-6709/G to a particular radio or crypto set, refer to table 1-1. This table lists the cable part

numbers and connector designations for radio and crypto sets used with the C-6709/G.

Table 1-1. Cable Requirements

Radio/crypto	Cable part No.	C-6709/G connector	Radio/crypto connector
AN/GRC-106	SM-D-938135	RADIO SIG	AUDIO
AN/GRC-193	SM-D-938075	RADIO SIG	AUDIO
AN/MRC-138	SM-D-938075	RADIO SIG	AUDIO
AN/PRC-70	SM-D-938075	RADIO SIG	AUDIO
AN/PRC-77	SM-D-938075	RADIO SIG	AUDIO
AN/PRC-104	SM-D-938075	RADIO SIG	AUDIO
AN/SRC-20A	SM-D-938137	RADIO SIG	HANDSET CONNECTOR
AN/SRC-21A	SM-D-938137	RADIO SIG	HANDSET CONNECTOR
AN/URC-93V	SM-D-938137	RADIO SIG	HANDSET CONNECTOR
AN/VRC-12	SM-D-938075	RADIO SIG	RE-TRANSMIT R/W MIKE
AN/VRC-43 thru AN/VRC49	CX-4723/VRC (9 ft) & SM-D-938075	INT RADIO PWR RADIO SIG	Not labeled
TSEC-KY-38	SM-D-938075	RADIO SIG	RE-TRANSMIT R/W MIKE
TSEC-KY-57	SM-D-938075	RADIO SIG	AUDIO
TSEC-KY-65	SM-D-938075	RADIO SIG	HANDSET

Change 1 1-3/(1-4 blank)

**CHAPTER 2
INSTALLATION INSTRUCTIONS**

2-1. Checking Unpacked Equipment

a. Inspect the equipment for damage incurred during shipment. If the equipment has been damaged, report the damage on SF 364 (para 1-3 b).

b. Check the equipment against the major component listing (par 1-10) and the packing slip to see if the shipment is complete. Report all discrepancies in accordance with paragraph 1-2. The equipment should be placed in service even though a minor assembly or part that does not affect proper functioning is missing.

c. Check to see whether the equipment has been modified. (Equipment which has been modified will have the MWO number on the front panel.) Check also to see whether all currently applicable MWO's have been applied. (Current MWO's applicable to the equipment are listed in DA Pam 310-1).

2-2. General Installation Instructions

The C-6709/G is completely contained in a single enclosure.

NOTE

Before mounting the C-6709/G to any surface, such as that of a vehicle, appropriate authorization should be obtained.

If the C-6709/G is to be vehicle mounted, the mounting brackets provided must be attached to the case.

2-3. Tools, Test Equipment, and Materials Required

Installation of this equipment must be performed by organizational maintenance personnel. Refer to table 2-1 for tools, test equipment, and materials required for installation but not part of the C-6709/G.

Table 2-1. Tools, Test equipment and Materials

Items	Purpose	Applicable publications
Tool Kit, Electronic Equipment TK-101/G	Installation	SC 5180-91-C1-R13
Multimeter AN/USM-223	Check operating voltages	TM 11-6625-654-14
Ground wire	Ground equipment
Hardware	Attach equipment to mounting surface
(4) 1/4-20 Hex Nuts*	
(4) 1/4-20 X 2 Hex Head Screws*	
(4) 1/4 Lockwashers*	
(6) 5/16-18 Hex Nuts**	
(6) 5/16-18 X 1 inch Hex Screws*	
(6) 5/16 Lockwasher**	
(6) 5/10 Flat Washer**	
3/8" electric drill	Drill holes for mounting
5/16-18 Tap**	Tap holes in mounting surface
1/4-20 Tape*	Tap holes in mounting surface
Tap Wrench	Tap holes in mounting surface
#F Twist Drill**	Drill mounting holes
#7 Twist Drill	Drill mounting holes

*Used for older style bracket for attaching to vertical surface

**Used for newer style bracket for attaching to horizontal surface

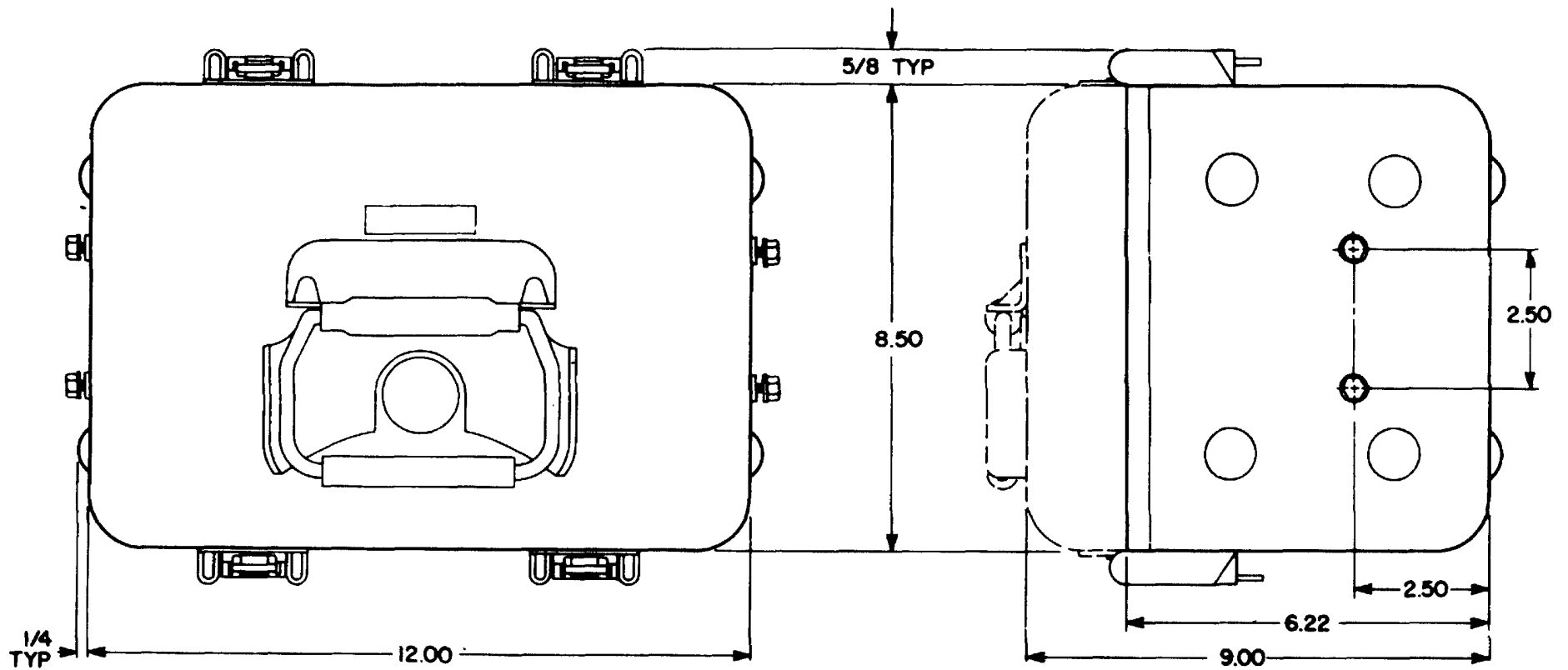

NOTE:
ALL DIMENSIONS ARE IN INCHES.

EL4NM002

Figure 2-1. Outline drawing of Control, Radio Set C-6709/G.

2-4. Installation

a. A relief valve is located on the front cover of this equipment. Press the red button to relieve air pressure.

WARNING

The latches are under spring tension. Be careful when releasing them to avoid injury.

b. Remove the front cover by setting the unit on its back, and releasing the four latches.

NOTE

Steps c through g provide information on installing mounting kit part no. SM-C-938091, figure 2-2. Steps h through k provide information on installing mounting brackets part no. B4014322 and B4014323, figure 2-2.1. Step 1 lists the kit number of the other brackets used for specific installations.

c. Remove the two mounting brackets from the canvas bag.

d. Refer to figure 2-2. With a hex wrench from the tool kit, loosen the hex head screws on the sides of the case so that there is about 1/4 inch between the lockwashers and case.

e. Slip the keyhole slots of the mounting brackets over the screwheads, and push the bracket against the body of the screw. Tighten the screwheads so that the brackets are secure.

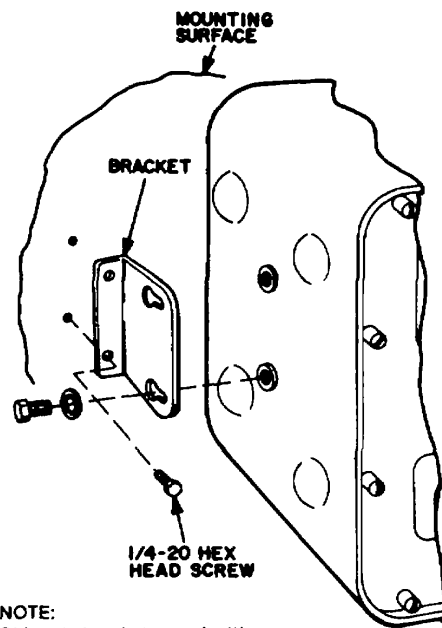

NOTE:
Old style brackets used with previously manufactured units.

EL4NM007

Figure 2-2. Attaching mounting brackets, part no. SM-C-938091

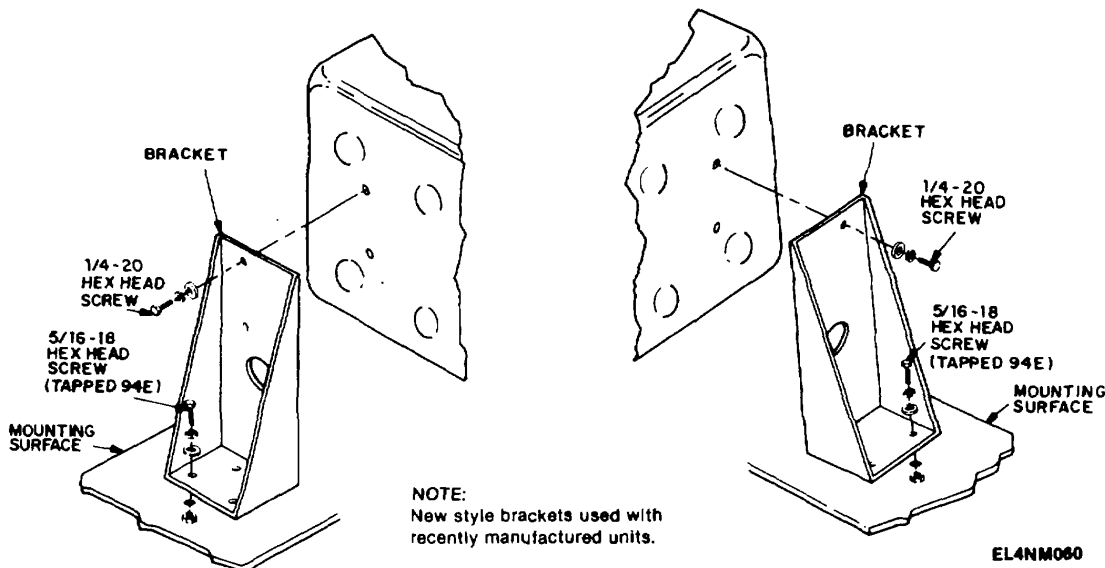

NOTE:
New style brackets used with recently manufactured units.

EL4NM060

Figure 2-2.1. Attaching mounting brackets, part no. 84014322 and 84014323.

f. Locate a mounting area with 1/4 -20 tapped holes spaced as shown in figure 2-3. If such holes are not available near the radio set, mounting must be provided either by drilling four #7 holes and tapping with a 1/4-20 tap (in metal approximately 3/16-inch thick), or drilling four 5/16-inch holes in sheet metal and securing the C-6709/G with screws, lockwashers, and nuts. To drill holes, always center punch the exact location before drilling.

g. Mount the C-6709/G by means of the screws, lockwashers, and nuts if needed as shown in table 2-1. Use the spin tite, in the toolkit, to tighten the screws.

h. Remove the two mounting brackets from the canvas bag.

i. Refer to figure 2-2 for bracket mounting on the C-6709/G.

j. Locate a mounting area with 5/16-18 tapped holes spaced as shown in figure 2-3.1. If such holes are not available near the radio set, mounting must be provided either by drilling six # F holes and tapping with a 5/16-18 tap (in metal approximately 3-16-inch thick), or drilling six 21/64-inch holes in sheet metal and securing the C-6709/G with screws, lockwashers, and

nuts. To drill holes, always center punch the exact location before drilling.

k. Mount the C-6709/G by means of the screws, lockwashers, and nuts if needed as shown in table 2-1. Use the spin tite, in the toolkit, to tighten the screws.

l. The bracket kit numbers listed in table 2-2 are for mounting bracket used for specific installation.

Table 2-2. Mounting Kits

Kit No.	NSN	Application
MK-2118/VRC	5820-01-145-8508	For M-151 Vehicle Installation
MK-2117/VRC	5820-01-144-5990	For 19 inch Rack Mounting (M-882)
MK-2118/VRC	5820-01-144-5991	For Tracked Vehicle Mounting
MK-2245/VRC	5820-01-159-1774	For 1-1/4 Ton Truck M-561

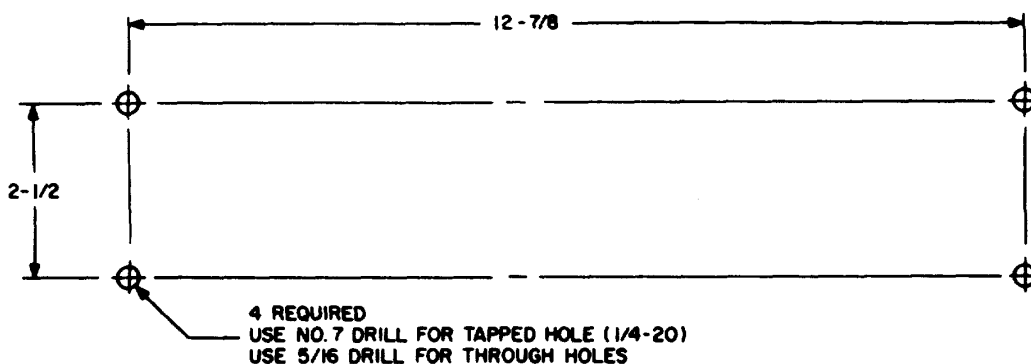

NOTE:

ALL DIMENSIONS ARE IN INCHES

EL4NM008

Figure 2-3. Mounting Hole Spacing for bracket kit part no. SM-C-938091.

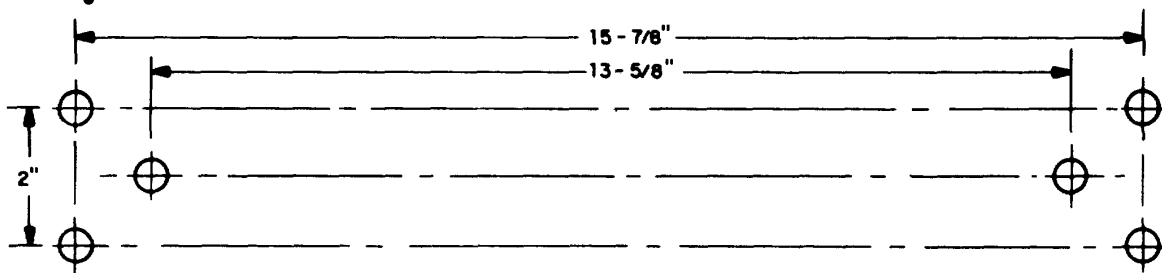

Figure 2-3.1. Mounting Hole Spacing for bracket kit part nos. 84014322 and 84014323.

EL4NM061

2-5. Cable Connections

The C-6709/G is designed to be cable connected to a radio set, and wire connected to a switchboard. Power is obtained either from the radio set, through a power cable, or from an external 24-vdc power supply.

2-6. Interconnections

a. Remove the cables and headset from canvas bag, and place front cover in bag.

b. Install ground wire under wingnut (GND) on front panel. Be sure a proper vehicle connection is obtained. Use WD-I or equivalent wire for connection

WARNING

Long field wires are subject to lightning strikes. Do not connect or disconnect signal lines during lightning conditions.

c. Set the PWR INT-OFF-EXT toggle switch to OFF.

CAUTION

Be careful when connecting RADIO SIG and TM11-5820.615-12 HEADSET cable plugs. Both receptacles are identical.

d. Connect the RADIO SIG cable plug and HEADSET plug to the respective receptacles on the left side of the front panel.

e. For AN/VRC-12 and AN/VRC-43 through AN/VRC-49 radio sets, insert the INT RADIO PWR cable plug into the large receptacle (upper left corner of panel). Rotate the handle on the plug to lock in place.

NOTE

If it is difficult to insert any connector into its receptacle, slightly dampen the O-ring on the inside of the receptacle with water.

f. To identify correct receptacles on the radio or crypto sets, refer to paragraph 1-11, then connect cables as indicated.

g. Connect the send pair and the receive pair of wires from the 4-wire switchboard to the RED and BLACK binding posts, respectively as shown in figure 2-4.

Change 1 2-4.1/(2-4.2 Blank)

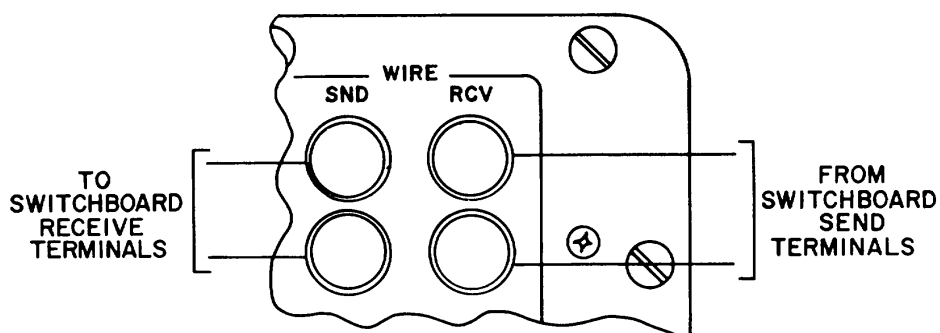

EL4NM004

Figure 2-4. Switchboard send and receive wire connections.

h. Connect the external power supply (if used) to the screwdriver) to the position indicated in table 2-2, for the EXT 24 Vdc binding posts (negative to (-), positive to (+)) as shown in fig. 2-5. Use standard field wire, WD-1 or equivalent, for connections.

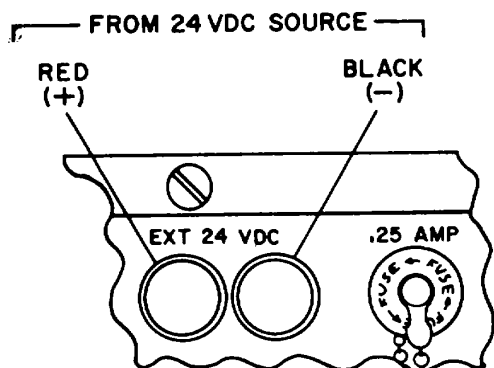

EL4NM005

Figure 2-5. External Power Connection.

2-7. Preliminary Adjustment

Set the RADIO LEVEL switch (with a flat blade screwdriver) to the position indicated in table 2-2, for the radio set in use. A copy of the table is mounted in the front cover of the equipment.

Table 2.2. Radio level switch/equipment interface chart

RADIO LEVEL switch position	Equipment nomenclature
1	AN/URC-93V
2	AN/SRC-20A
2	AN/SRC-21 A
3	AN/GRC-106
4	AN/PRC-70
4	AN/PRC-77
4	AN/VRC-12
4	AN/VRC-43 through AN/VRC-49
5	AN/PRC- 104
5	AN/MRC-138
5	AN/GRC- 193
6	TSEC-KY-65
7	TSEC-KY-38
8	TSEC-KY-57

2-8. Preliminary Checks

- Perform the preliminary checks as shown in table 2-3.
- Equipment is now ready for operation.
- Check operation by using normal operating procedures (chap. 3).

Table 2-3. Installation check procedure

Item	Checks
Ground Wire	Determine that the wire is securely connected to GND terminal on the front panel, and that a proper vehicle ground is established. Check continuity to vehicle chassis.
RADIO SIG	Determine that connectors are properly seated in the correct receptacles.
HEAD SET	Determine that connectors are properly seated in the correct receptacles.
INT RADIO PWR (if needed)	Determine that the connector is properly seated in the receptacle, and that the handle is positioned to lock it in place.
SND RCV Wire	Determine that pairs are properly connected to the correct binding posts.
EXT 24 Vdc Wires (if needed)	Determine that wires are properly connected to the binding posts (observe polarity).

Table 2-3. Installation check procedure-Continued

<i>Item</i>	<i>Checks</i>
RADIO LEVEL switch	Determine that the switch is in the proper position for radio set being used.
RADIO SET	Determine that connectors are properly seated in receptacles.
LIGHTNING ARRESTOR (ESA)	Request higher level maintenance to test ESA's.

CHAPTER 3 OPERATING INSTRUCTIONS

Section I. OPERATION UNDER USUAL CONDITIONS

3-1. General

The chart in paragraph 3-2 describes the controls, indicators, and connectors on the C-6709/G front panel.

This equipment will withstand any combination of control settings.

3-2. Operator/Crew Controls and Indicators (fig. 3-1)

<i>Control indicator or connector</i>	<i>Function</i>
Keysender-16 pushbutton	Permits sending dual tone, multiple frequency tones (DTMF) into an automatic switchboard. Permits C-6709/G operator to key radio transmitter on and off.
.25 AMP fuse	Provides protection to both internal (radio) power supply and external power supply.
RLSE pushbutton switch	Pressing and releasing pushbutton sends a 2600-Hz release signal until release acknowledge signal is received.
SVC REQ/BUSY lamp	Indicates service request, and busy/idle status of equipment. Lamp flashes for service request and lights continuously to indicate a busy condition.
OPER CONNECT: SWBD pushbutton switch	Enables the operator to monitor and talk with switchboard side of link and originate a call to the switchboard.
RADIO pushbutton switch	Enables the operator to monitor or talk with radio side of link.
CALL CONNECT: OPER IN pushbutton switch	Enables the operator to connect to talkpath and connect the switchboard to the radio.
OPER OUT pushbutton switch	Enables operator to remove himself from talkpath and connect the switchboard to the radio.
Mode (4 position) rotary switch (located above the keysender)	Permits the operator to selector the method of keying the radio transmitter on and off.
SF/(PTT) single frequency press-to-talk switch	Pressing the PTT button on a digital telephone will key the transmitter on, and when released, will key the transmitter off.
DTMF 1/3	Permits remote switchboard operator to key the transmitter on by pressing the Of I button of his keysender, and key the transmitter off by pressing the 3 button.
AVOX automatic voice-operated switch	Transmitter is keyed on when the switchboard subscriber speaks and off when he is silent.
OPER	When the switch is in this position, the C-6709/G operator keys the transmitter on when he presses the # 1 button of his keysender. The transmitter is keyed off by pressing the 3 button. The operator can override the receiver squelch. When the H-250 handset is used, pressing the PTT button will key the transmitter on, and releasing the PTT button will key the transmitter off.
INT RADIO PWR receptacle	Connects the dc power cable to the radio set (AN/VRC-12 family).
CALL ALARM	(left of SVC REQ lamp) Sounds when service is requested, if control is not in OFF position.
CALL ALARM volume control	Adjust the CALL ALARM sound level from OFF to LOUD.
INT-OFF-EXT toggle switch	Selects the power source for the C-6709/G.
INT	In this position the radio set provides the power.
OFF	In this position, power is OFF, and the unit is inoperative.
EXT	In this position, power is obtained through two binding posts marked EXT 24 VDC (+) and (-).
EXT 24 VDC binding posts	Connection for external battery. Battery (+) connects to red binding post and battery (-) connects to black binding post.
RADIO SIG receptacle	Audio and control signals are fed to the radio set via the interconnecting cable.
HEAD SET receptacle and volume control	The H-325/TTC headset/microphone cable plug or, if used, the 11-250 handset microphone cable plug, is installed in this receptacle. The control adjusts the headset volume from OFF to LOUD.
RADIO LEVEL rotary switch	This screwdriver actuated switch matches the C-6709/G to the radio set being used (table 2-2).
SND RCV binding posts	These binding posts are for connecting to the 4-wire switchboard. The send pair from the switchboard connect to the RCV posts (red). The receive pair from the switchboard connects to the SND (black) posts.
GND terminal	Attach facility ground wire (earth) to wingnut terminal on the panel.

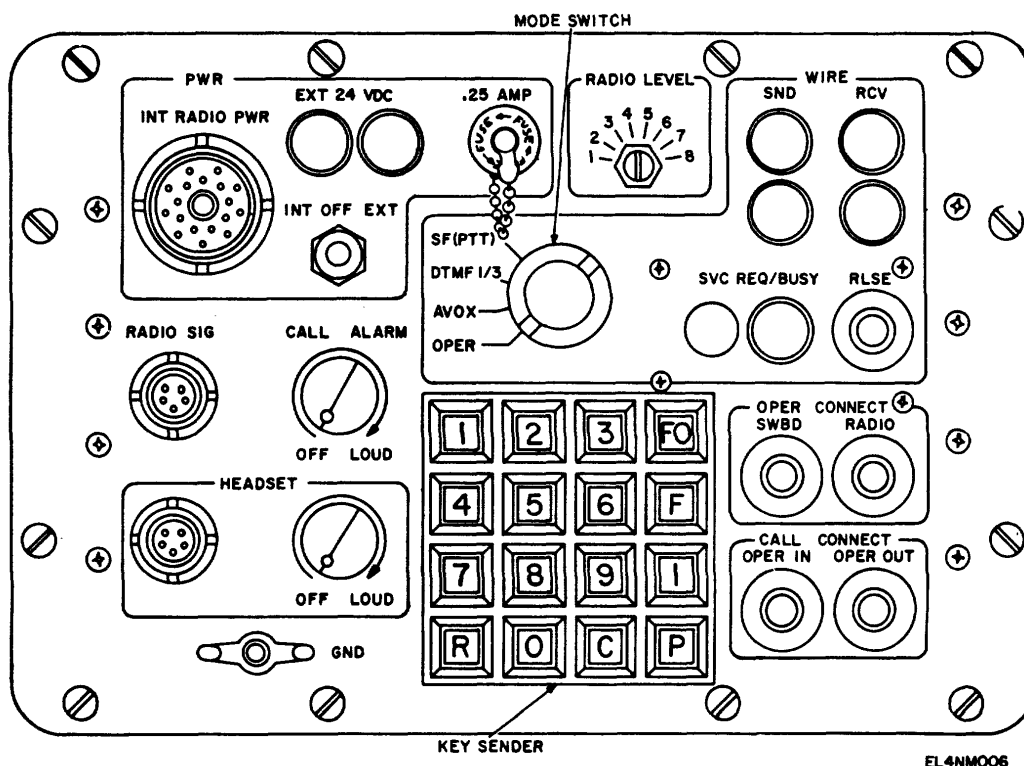

Figure 3-1. Operating controls and indicators.

3-3. Preliminary Starting Procedure

- a. Set the mode switch in the OPER position.
- b. Set the INT-OFF-EXT switch as follows: If the INT RADIO PWR cable is connected to the radio set, place the switch in the INT position. If this cable is not connected, place the switch in the EXT position.
- c. Set the CALL ALARM and HEADSET volume controls to midposition.
- d. Press OPER CONNECT RADIO pushbutton.

3-4. Operating Procedures

a. *Call Originating From a Switchboard.* The C-6709/G operator receives a call indicated by the audible alarm, and flashing SVC REQ/BUSY lamp. The operator presses the OPER CONNECT SWBD button. The SVC REQ/BUSY lamp should stop flashing and remain illuminated. The C-6709/G operator should now obtain the needed information from the switchboard operator such as the party to be called and the type of transmitter control desired. The operator presses the OPER CONNECT RADIO button and sets the radio to the proper frequency. The C-6709/G operator now keys

the radio transmitter to 3-2 ON and OFF by pressing the 1 and 3 buttons, respectively, of his keysender or by the PFIT button on the H-250 headset, if used. After making contact with the radio link, the C-6709/G operator presses the CALL CONNECT IN or OUT button, depending upon whether or not he desires to monitor both sides of the call, and sets the mode switch to the position requested by the switchboard subscriber. This completes the interconnect. When the call is completed, the SVC REQ/BUSY lamp should extinguish. If it does not within a reasonable length of time, the C-6709/G operator should press the CALL CONNECT OPER IN button. If the call is complete, the C-6709/G operator presses the RSLE button, thereby resetting the C-6709/G to receive other calls.

b. *Call Originating From a Radio Link.* When the C-6709/G operator receives a radio request for a call to be placed to the switchboard, he uses the following procedure:

- (1) Press the OPER CONNECT RADIO pushbutton, and rotate the mode switch to the OPER position. The headset and microphone are now disconnected from

the switchboard talkpath, and connected to the radio talkpath.

(2) The C-6709/G operator speaks to the radio caller by keying the transmitter on (pressing the 1 button on the keysender). He obtains necessary information such as the called party's number. The # 3 button keys the transmitter off.

(3) The operator presses the OPER CONNECT SWBD button thereby placing his headset in the switchboard talkpath and automatically initiating a seize sequence.

(4) The SVC REQ/BUSY lamp is constantly illuminated.

(5) The C-6709/G operator hears dial tone in his headset, and keys in the number of the called party on his keysender. When the first digit is received by the switchboard, dial tone is stopped. When the last digit has been pressed, ringback tone (interrupted 425 Hz) is heard in the C-6709/G headset.

NOTE

In case of a misdialled number, press RLSE to initiate a release sequence, then press OPER CONNECT SWBD to initiate a new seize sequence and redial number.

(6) When the called party answers, the C-6709/G operator informs him that he has a radio call,

and to use the # 1 and # 3 buttons on his keysender respectively to key the radio transmitter on and off.

(7) The C-6709/G operator may remove himself from the call by pressing the CALL CONNECT OPER OUT button and setting the mode switch to the desired position.

(8) When the called party hangs up, release is normally automatic, and SVC REQ/BUSY lamp is extinguished. If not, manual release will be necessary.

(9) If under conditions of very high noise level, the radio squelch control prevents operation, the C-6709/G operator should rotate the mode switch to the OPER position, monitor the call, and key the transmitter on and off.

NOTE

In the OPER position of the mode switch, only the C-6709/G operator can key the radio transmitter on and off.

3-5. Standby and Shutdown

a. Standby. Whenever calls are not being routed by the C-6709/G, the system is automatically in standby condition.

b. Shutdown. Place the INT-OFF-EXT switch in the OFF position. The unit is then completely shut down.

Section II. OPERATION UNDER UNUSUAL CONDITIONS 0?5

3-6. Operation Under Extreme Environmental Conditions

The C-6709/G is capable of operation under any climatic conditions; however, under extreme conditions the following precautions should be observed:

a. Cold Climates. Extremely low temperatures cause cables to become hard, brittle, and difficult to handle. Avoid kinks which would result in permanent damage. Be sure that all connectors are free of frost, snow, and ice.

b. Hot, Dry Climates. Under these conditions, connectors are subject to damage from dust and sand. Do not place open connectors on the ground.

c. Hot, Damp Climates. Under these conditions, the equipment is subject to damage from moisture and

fungi. Remove such contaminants with a clean, dry, lint-free cloth.

3-7. Operation Under Emergency Conditions

If the C-6709/G is operating with internal (radio set) power and the power cable malfunctions, the C-6709/G may be operated from an external power supply.

a. Connect an external 24-vdc power supply to the EXT 24 VDC binding posts, observing polarity (negative (black); positive (red)).

b. Place the INT--OFF-EXT switch in the EXT position, and the C-6709/G is ready to operate.

Table 4-1. Operator/Crew Preventive Maintenance Checks and Services-Continued
B - Before **D - During**

Item No.	Interval		Item to be Inspected.	Procedures	Equipment Is Not Ready Available If
	B	D			
14		•	e. OPER	buttons 1 and 3. Operator keys transmitter with the H-250 handset PTT button.	transmitter in OPER mode. Operator is unable to key transmitter in OPER mode.
15		•	Keysender	Check for DTMF tones sent to switchboard.	
16		•	RLSE pushbutton	Operator terminates a call.	
17		•	SVC-REQ/BUSY lamp	Check that lamp flashes when call is requested.	

4-5. Troubleshooting

a. The operator troubleshooting is limited to replacement of the fuse or the SERV REQ/BUSY lamp. If equipment is completely inoperative, the operator can change the fuse to check for failure due to blown fuse. The failure of the SERV REQ/BUSY lamp will be indicated by receipt of an audible alarm indicating a service request but no illumination of the SERV REQ/BUSY lamp. The operator should first insure that the lamp dimmer has not been turned preventing illumination. Spare lamp and fuse are stored in the small canvas bag in the cover.

b. Any trouble that is beyond the scope of operator/crew shall be referred to organizational maintenance.

4-6. Maintenance of Control, Radio Set C-6709/G

The operator/crew shall replace a blown fuse or a faulty SERV REQ/BUSY lamp. Replace lamp and fuses as follows:

a. Replacing Lamp

(1) Place EXT-OFF-INT switch in OFF position.

(2) Turn lens cap counterclockwise and remove it from the panel.

(3) Remove lamp from lens cap.

(4) Insert and seat new lamp.

(5) Reinstall lens cap.

(6) Return EXT-OFF-INT switch to EXT or INT position as applicable.

b. Replacing Fuse

(1) Place EXT-OFF-INT switch in OFF position.

(2) Turn fuse cap counterclockwise and remove it from panel.

(3) Remove blown fuse from fuseholder by pulling straight out.

(4) Insert new fuse into fuseholder.

(5) Reinstall fuseholder cap by rotating clockwise to secure.

(6) Return EXT-OFF-INT switch to EXT or INT as applicable.

**CHAPTER 5
ORGANIZATIONAL MAINTENANCE INSTRUCTIONS**

5-1. Organizational Tools and Equipment

The tools and equipment needed for organizational maintenance are listed in (IM 11-5805-615-20P). The maintenance allocation chart is in appendix D.

5-2. Repainting and Refinishing Instructions

CAUTION

Before painting, carefully mask all unpainted and vented surfaces and nameplates, decals, MWO information, and other markings.

a. The final paint film of both the front panel and the case is smooth, semigloss enamel, dark green color number 24087, conforming to FED-STD-595 as listed in SB 11-573. The finish for handles, hinges, screws, etc, is in accordance with MIL-F-14072.

b. Refer to TB 43-0118 for instructions on painting and preserving electronic equipment.

5-3. Organizational Preventive Maintenance Checks and Services

Organizational preventive maintenance should be performed at quarterly intervals in accordance with table 5-1.

NOTE

If the equipment must be kept in continuous operation, check and service only those items that can be checked and serviced without disturbing operation; make the complete services when the equipment can be shut down. Check external power source for 24 vdc minimum before reporting defective items to higher category maintenance personnel.

Table 5-1. Organizational Preventive Maintenance Checks and Services Quarterly Schedule

Item No.	Item To Be Inspected	Procedures
1	External surfaces	Check external surfaces for corrosion, moisture, mildew, dirt, grease, etc., clean as required.
2	Cover	Check cover and gasket for tears, cuts, and breaks.
3	Mounting	Check for loose screws and, mounting hardware.
4	Wiring and cables	Inspect cables for abrasions and broken or loose connections
5	Preservation	Inspect for rust and corrosion. Refinish as required.

5-4. Organizational Troubleshooting

Organizational troubleshooting is limited to replacement

of fuses, lamp, cables and headset. Refer to table 5-2 for organizational troubleshooting.

Table 5-2. Organizational Troubleshooting

	Malfunction	Probable cause	Corrective action
1	No communication possible with power toggle switch in either INT or EXT position	Defective .25 AMP fuse.	Replace fuse.
2	Operates only on EXT power	Defective INT RADIO PWR cable.	Replace cable.
3	Does not operate with EXT batteries	Defective batteries or connecting wires.	Replace batteries or wires as needed.
4	Operates in SWBD mode, but not in RADIO mode	Defective RADIO SIG cable.	Replace cable.
5	Operation normal, but SVC REQ/BUSY lamp does not light	Defective lamp.	Replace lamp.
6	Switchboard and radio audio not present in headset	Headset defective.	Replace headset.

5-5. Preparation for Storage

Before placing the C-6709/G in storage, inspect it for completeness and appearance. Also, check to be sure that it meets all operational requirements.

a. Perform the operator/crew preventive maintenance checks and services (table 4-1).

b. Perform the organizational maintenance checks and services (table 5-1).

**APPENDIX A
REFERENCES**

AR 55-38	Reporting of Transportation Discrepancies in Shipments.
AR 700-58	Reporting of Packaging and Handling Deficiencies.
DA Pam 310-1	Consolidated Index of Army Publications and Blank Forms.
DA Pam 738-750	The Army Maintenance Management System (TAMMS).
SB 11-573	Painting and Preservation of Supplies Available for Field Use for Electronics Command Equipment.
SB 38-100	Preservation, Packaging, Packing and Marking Materials, Supplies, and Equipment Used by the Army.
SB 700-20	Army Adopted/Other Items Selected for Authorization/List of Reportable Items.
TB SIG 222	Solder and Soldering.
TB 43-0116	Identification of Radioactive Items in the Army Supply System.
TB 43-0118	Field Instructions for Painting and Preserving Electronics Command Equipment including Camouflage Pattern Painting of Electrical Equipment Shelters.
TM 11-5805-615-20P	Repair Parts and Special Tools List for Control, Radio Set C-6709/G.
TM 740-90-1	Administrative Storage of Equipment.
TM 750-244-2	Procedures for Destruction of Electronics Materiel to Prevent Enemy Use (Electronics Command).

Change 1 A-1/(A-2 blank)

APPENDIX B COMPONENTS OF END ITEM LIST

Section I. INTRODUCTION

B-1. Scope

This appendix lists integral components of and basic issue items for the C-6709/G to help you inventory items required for safe and efficient operation.

B-2. General

This Components of End Item List is divided into the following sections:

a. Section II. Integral components of the End Item. These items, when assembled, comprise the C-6709/G and must accompany it whenever it is transferred or turned in. The illustrations will help you identify these items.

b. Section III. Basic Issue Items. These are the minimum essential items required to place the C-6709/G in operation, to operate it, and to perform emergency repairs. Although shipped separately packed they must accompany the C-6709/G during operation and whenever it is transferred between accountable officers. The illustrations will assist you with hard-to-identify items. This manual is your authority to requisition replacement BII, based on TOE/MTOE authorization of the end item.

B-3. Explanation of Columns

a. Illustration. This column is divided as follows:

(1) Figure number. Indicates the figure number of the illustration on which the item is shown.

(2) Item number. The number used to identify item called out in the illustration.

b. National Stock Number. Indicates the National stock number assigned to the item and which will be used for requisitioning.

c. Part Number. Indicates the primary number used by the manufacturer, which controls the design and characteristics of the item by means of its engineering

drawings, specifications, standards, and inspection requirements to identify an item or range of items. Following the part number, the Federal Supply Code for Manufacturers (FSCM) is shown in parentheses.

d. Description. Indicates the Federal item name and, if required, a minimum description to identify the item.

e. Location. The physical location of each item listed is given in this column. The lists are designed to inventory all items in one area of the major item before moving on to an adjacent area.

f. Usable on Code. Not applicable.

g. Quantity Required (Qty Reqd). This column lists the quantity of each item required for a complete major item.

h. Quantity. This column is left blank for use during an inventory. Under the Rcvd column, list the quantity you actually receive on your major item. The Date columns are for your use when you inventory the major item at a later date; such as for shipment to another site.

B-4. Special Information

National stock numbers (NSN's) that are missing from P source coded items have been applied for and will be added to this TM by future change/revision when they are entered in the Army Master Data File (AMDF). Until the NSN's are established and published, submit exception requisitions to: Communications and Electronics Materiel Readiness Command, ATTN: DRSEL-MM, Fort Monmouth, New Jersey 07703 for the part required to support your equipment.

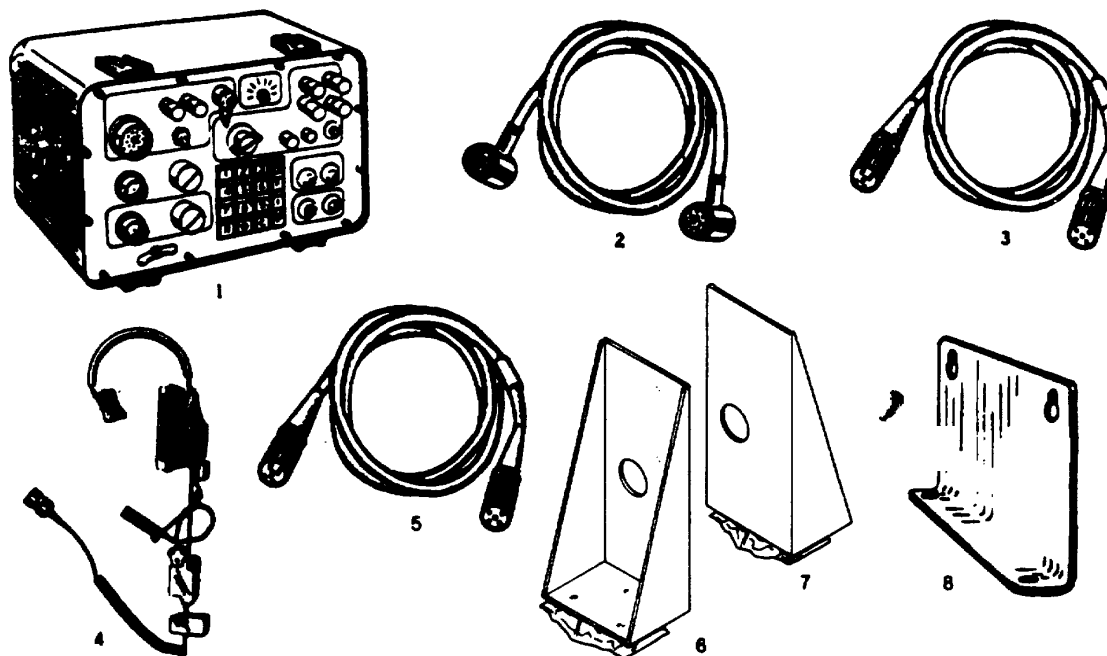

Figure B-1

Section II. INTEGRAL COMPONENTS OF END ITEM

(1) ILLUS	(2) NATIONAL STOCK NUMBER	(3) DESCRIPTION (FSCM) AND PART NUMBER	(4) U/M	(5) QTY REQD
B-1, 1	5820-00-930-3597	CONTROL, RADIO SET C-6709/G (80058)		1
B-1, 2	5595-00-823-2834	CABLE ASSEMBLY, CX4723() / VRC (9 FT) IN CANVAS BAG (80058) SM-D-415553		1
B-1, 3		CABLE ASSEMBLY IN CANVAS BAG (80063) SM-D-938075		1
B-1, 4	5965-00-186-1194	HEADSET-MICROPHONE H-325/TTC IN CANVAS BAG (80058)		1
B-1, 5		CABLE ASSEMBLY IN CANVAS BAG (80063) SM-D-938135		1
B-1, 6	5430-01-137-7108	MOUNTING BRACKET (LH) IN CANVAS BAG (56996) B4014322		1
B-1, 7	5340-01-139-2090	MOUNTING BRACKET (RH) IN CANVAS BAG (56996) B4014323		1
B-1, 8		MOUNTING BRACKET IN CANVAS BAG (80063) SM-C-938091		2

*Old style mounting bracket.

NOTE:

Items 1, 2, 3, 4, 5, 8 and 7 are shipped with recently manufactured units of the end item.

Items 1, 2, 3, 4 and 8 have been shipped with units purchased previously.

SECTION III BASIC ISSUE ITEMS

(1) ILLUSTRATION		(2) QTY NATIONAL STOCK NUMBER	(3) DESCRIPTION		(4) LOCATION	(5) USABLE ON CODE	(6) QTY REQD	(7) QTY	
(a) FIG NO.	(b) ITEM NO.		PART NUMBER	FSCM				RCVD	DATE
			BAG, CANVAS	(80063)			1		
		5920-00-190-3348	SM-C-938086						
			FUSE FM 03-250V-1/4A	(81349)	IN CANVAS BAG		3		
			TM 11-5820-615-12				1		
		5975-00-158-8487	LAMP, 370	(08806)	IN CANVAS BAG		3		

APPENDIX C
ADDITIONAL AUTHORIZATION LIST
Section I. INTRODUCTION

C-1. Scope

This appendix lists additional items you are authorized for the support of the C-6709/G.

C-2. General

This list identifies items that do not have to accompany the C-6709/G and that do not have to be turned in with

it. These items are all authorized to you by CTA, MTOE, TDA, or JTA.

C-3. Explanation of Listing

National stock numbers, descriptions, and quantities are provided to help you identify and request the additional items you require to support this equipment.

(Next printed page is C-2)

SECTION II ADDITIONAL AUTHORIZATION LIST

(1) NATIONAL STOCK NUMBER	(2) DESCRIPTION PART NUMBER AND FSCM USABLE ON CODE	(3) U/M	(4) QTY AUTH
	CABLE ASSEMBLY SM-D-938137 AN/SRC-20A AN/SRC-21A AN/URC-93V	EACH	1

APPENDIX D MAINTENANCE ALLOCATION

Section I. INTRODUCTION

D-1. General

This appendix provides a summary of the maintenance operations for the C-6709/G. It authorizes categories of maintenance for specific maintenance functions on repairable items and components and the tools and equipment required to perform each function. This appendix may be used as an aid in planning maintenance operations.

D-2. Maintenance Function

Maintenance functions will be limited to and defined as follows:

a. Inspect. To determine the serviceability of an item by comparing its physical, mechanical, and/or electrical characteristics with established standards through examination.

b. Test. To verify serviceability and to detect incipient failure by measuring the mechanical or electrical characteristics of an item and comparing those characteristics with prescribed standards.

c. Service. Operations required periodically to keep an item in proper operating condition, i.e., to clean (decontaminate), to preserve, to drain, to paint, or to replenish fuel, lubricants, hydraulic fluids, or compressed air supplies.

d. Adjust. To maintain, within prescribed limits, by bringing into proper or exact position, or by setting the operating characteristics to the specified parameters.

e. Align. To adjust specified variable elements of an item to bring about optimum or desired performance.

f. Calibrate. To determine and cause corrections to be made or to be adjusted on instruments or test measuring and diagnostic equipments used in precision measurement. Consists of comparisons of two instruments, one of which is a certified standard of known accuracy, to detect and adjust any discrepancy in the accuracy of the instrument being compared.

g. Install. The act of emplacing, seating, or fixing into position an item, part, module (component or assembly) in a manner to allow the proper functioning of the equipment or system.

h. Replace. The act of substituting a serviceable like type part, subassembly, or module (component or assembly) for an unserviceable counter part.

i. Repair. The application of maintenance services (inspect, test, service, adjust, align, calibrate, replace) or other maintenance actions (welding, grinding, riveting, straightening, facing, remachining, or resurfacing) to restore serviceability to an item by correcting specific damage, fault, malfunction, or failure in a part, subassembly, module (component or assembly); end item, or system.

j. Overhaul. That maintenance effort (service/action) necessary to restore an item to a completely serviceable/operational condition as

prescribed by maintenance standards (i.e., DMWR) in appropriate technical publications. Overhaul is normally the highest degree of maintenance performed by the Army. Overhaul does not normally return an item to like new condition.

k. Rebuild. Consists of those services/actions necessary for the restoration of unserviceable equipment to a like new condition in accordance with original manufacturing standards. Rebuild is the highest degree of materiel maintenance applied to Army equipment. The rebuild operation includes the act of returning to zero those age measurements (hours, miles, etc.) considered in classifying Army equipments/components.

D-3. Column Entries

a. Column 1, Group Number. Column 1 lists group numbers, the purpose of which is to identify components, assemblies, subassemblies, and modules with the next higher assembly.

b. Column 2, Component/Assembly. Column 2 contains the noun names of components, assemblies, subassemblies, and modules for which maintenance is authorized.

c. Column 3, Maintenance Functions. Column 3 lists the functions to be performed on the item listed in column 2. When items are listed without maintenance functions, it is solely for purpose of having the group numbers in the MAC and RPSTL coincide.

d. Column 4, Maintenance Category. Column 4 specifies, by the listing of a "work time" figure in the appropriate subcolumn(s), the lowest level of maintenance authorized to perform the function listed in column 3. This figure represents the active time required to perform that maintenance function at the indicated category of maintenance. If the number of complexity of the tasks within the listed maintenance function vary at different maintenance categories, appropriate "work time" figures will be shown for each category. The number of taskhours specified by the "work time" figure represents the average time required to restore an item (assembly, subassembly, component, module, end item or system) to a serviceable condition under typical field operating conditions. This time includes preparation time, troubleshooting time, and quality assurance/quality control time in addition to the time required to perform the specific tasks identified for the maintenance functions authorized in the maintenance allocation chart. Subcolumns of column 4 are as follows:

C-Operator/Crew
O-Organizational
F-Direct Support

H-General Support
D-Depot

e. Column 5, Tools and Equipment. Column 5 specifies by code, those common tool sets (not individual tools) and special tools, test, and support equipment required to perform the designated function.

f. Column 6, Remarks. Column 6 contains an alphabetic code which leads to the remark in section IV, Remarks, which is pertinent to the item opposite the particular code.

D-4. Tool and Test Equipment Requirements (Sec III)

a. Tool or Test Equipment Reference Code. The numbers in this column coincide with the numbers used in the tools and equipment column of the MAC. The numbers indicate the applicable tool or test equipment for the maintenance functions.

b. Maintenance Category. The codes in this column indicate the maintenance category allocated the tool or test equipment.

c. Nomenclature. This column lists the noun name and nomenclature of the tools and test equipment required to perform the maintenance functions.

d. National/NATO Stock Number. This column lists the National/NATO stock number of the specific tool or test equipment.

e. Tool Number. This column lists the manufacturer's part number of the tool followed by the Federal Supply Code for manufacturers (5-digit) in parentheses.

D-5. Remarks (Sec. IV)

a. Reference Code. This code refers to the appropriate item in section II, column 6.

b. Remarks. This column provides the required explanatory information necessary to clarify items appearing in section H.

(Next printed page in D-3)

**SECTION II MAINTENANCE ALLOCATION CHART
FOR
CONTROL, RADIO SET C-6709/G**

(1) GROUP NUMBER	(2) COMPONENT/ASSEMBLY	(3) MAINTENANCE FUNCTION	(4) MAINTENANCE LEVEL					(5) TOOLS AND EQUIPMENT	(6) REMARKS
			C	O	F	H	D		
00	CONTROL, RADIO SET C-6709/G	Inspect Test Service Install Replace Repair Overhaul	0.1	0.1 0.1 0.1	0.1 0.1			1, 2	
01	RADIO SET CONTROL SUBASSEMBLY	Inspect Test Replace Repair		0.1 0.5			10.0	1 thru 23 1, 2, 4, 5, 14, 20	A
0101	TRANS/OPR SUBASSEMBLY	Inspect Test Replace Repair			0.1 0.3			2 thru, C6 9, 12 2 thru 5, 9, 13	D
0102	TONE GENERATOR	Inspect Test Replace Repair			0.1 0.5			2, 3 2 thru 7, 9, 10.15 2, 3 2, 3, 5, 6, 7, 9, 10	
0103	LOGIC/POWER SUPPLY ASSEMBLY	Inspect Test Test Replace Repair			0.1 0.8	2, 3		2 thru 5, 7 8, 10, 11, 15, 16, 21 2, 3, 5, 8, 9, 10,	E F
0104	GROUP FILTER/DETECTOR ASSEMBLY	Inspect Test Test Replace Repair			0.1 0.2			2, 3 2 thru 5, 7, 12, 15 2 thru 7, 15 2, 3 2.3, 5, 7, 9, 12, 13, 15	G H
0105	AVOX SUBASSEMBLY	Inspect Test Replace Repair			0.1			2, 3 2 thru 5, 7, 12 2, 3 2 thru 6, 12	
0106	FRONT PANEL ASSEMBLY	Inspect Test Replace Repair		0.1 0.3				1, 2	
0107	CHASSIS ASSEMBLY	Inspect Test Repair Inspect Test Repair Repair			0.5 0.2 0.5	1, 2, 3		3, 9, 23 2, 3 1, 2, 3 3, 7, 18, 19, 22	I
02	POWER CABLE	Inspect Test Replace Repair	0.1	0.3 0.1	1, 2 0.3			1, 2	

**SECTION II MAINTENANCE ALLOCATION CHART
FOR
CONTROL, RADIO SET C-6709/G**

(1) GROUP NUMBER	(2) COMPONENT/ASSEMBLY	(3) MAINTENANCE FUNCTION	(4) MAINTENANCE LEVEL					(5) TOOLS AND EQUIPMENT	(6) REMARKS
			C	O	F	H	D		
03	AUDIO CABLE	Inspect Test Replace	0.1	0.1 0.1				1, 2	
04	HEADSET	Repair Inspect Test Replace Repair	0.1		0.2 1, 2 0.1			1, 2 3, 7	

**SECTION III TOOL AND TEST EQUIPMENT REQUIREMENTS
FOR**

CONTROL, RADIO SET C-6709/G

Tool Or Test Equipment Ref Code	Main Category	Nomenclature	National Stock Number	Tool Number
1	0	MULTIMETER AN/USM-223	6625-00-999-7465	
2	0	TOOL KIT ELECTRONIC EQUIPMENT TK-101/G	5180-00-064-5178	
3	F, H, D	TOOL KIT ELECTRONIC EQUIPMENT TK-100/G	5180-00-605-0079	
4	F, H, D	CARD EXTENDER (P/N 70A0061A01, FSCM 15412)	5120-01-073-9047	
5	F, H, D	POWER SUPPLY PP-3940/G (2 EACH)	6130-00-953-7500	
6	F, H, D	COUNTER, ELECTRONIC DIGITAL OUTPUT AN/USM-207A	6625-00-044-3228	
7	F, H, D	MULTIMETER ME-268/U	6625-00-646-9409	
8	F, H, D	DECADE RESISTOR BOX ZM-16/U	6625-00-669-0266	
9	F, H, D	MULTIMETER ME-30E/U	6625-00-643-1670	
10	F, H, D	OSCILLOSCOPE AN/USM-281C	6625-00-106-9622	
11	F, H, D	OSCILLATOR SG-299B/U	6625-00-808-5584	
12	F, H, D	AUDIO OSCILLATOR TS-421C/U	6625-00-435-2588	
13	D	SIGNAL GENERATOR AN/USM-205A	6625-01-007-4796	
14	F, H, D	600 OHM, 1W, 1% RESISTOR	5905-00-615-8872	
15	F, H, D	CLIP LEADS		
16	F, H, D	10K OHM, 1/4W, 5% RESISTOR	5905-00-106-3666	
17	F, H, D	150 OHM, 1W, 1% RESISTOR	5905-01-038-6308	
18	F, H, D	CRIMPING TOOL (P/N 06770011, FSCM 91662)	5120-01-073-9026	
19	F, H, D	EXTRACTOR (P/N 06769901, FSCM 91662)	5120-01-073-9027	
20	F, H, D	TELEPHONE SET TA-341A/TT (2 EACH)	5805-00-148-6933	
21	F, H, D	200 OHM, 2W, 5% RESISTOR	5905-00-146-8423	
22	F, H, D	INSERTION TOOL (P/N 06769801, FSCM 91662)	5120-01-073-9028	
23	F, H, D	TORQUE WRENCH, FSCM 09412	5120-00-931-8361	

SECTION IV. REMARKS

REFERENCE CODE	REMARKS
A	BY REPLACEMENT OF RADIO SET CONTROL SUBASSEMBLY A1
B	BY REPLACEMENT OF ASSEMBLIES A1A1 THROUGH A1A7
C	LOGIC TESTS
D	INPUT/OUTPUT AMPLITUDE RESPONSE TEST
E	LOGIC TEST
F	LOAD AND RIPPLE TESTS
G	FREQUENCY CHANGE OVER FREQUENCY DETECT
H	TOLERANCE TEST

APPENDIX E
EXPENDABLE SUPPLIES AND MATERIALS LIST

Section I. INTRODUCTION

E-1. Scope

This appendix lists expendable supplies and materials you will need to operate and maintain the Control, Radio Set C-6709/G. These items are authorized to you by CTA 50-970, Expendable Items (Except Medical, Class V, Repair Parts, and Heraldic Items).

E-2. Explanation of Columns

a. Column 1-Item Number. This number is assigned to the entry in the listing and is referenced in the narrative instructions to identify the material (e.g., "Use cleaning compound, item 5, App. D").

b. Column 2-Level. This column identifies the lowest level of maintenance that requires the listed item.

C-Operator/Crew

O-Organizational Maintenance

F-Direct Support Maintenance

H-General Support Maintenance

c. Column 3-National Stock Number. This is the National stock number assigned to the item; use it to request or requisition the item.

d. Column 4-Description. Indicates the Federal item name and, if required, a description to identify the item. The last line for each item indicates the part number followed by the Federal Supply Code for Manufacturer (FSCM) in parentheses, if applicable.

e. Column 5-Unit of Measure (U/M). Indicates the measure used in performing the actual maintenance function. This measure is expressed by a two-character alphabetical abbreviation (e.g., ea, in, pr). If the unit of measure differs from the unit of issue, requisition the lowest unit of issue that will satisfy your requirements.

SECTION II. EXPENDABLE SUPPLIES AND MATERIALS LIST

(1) ITEM NUMBER	(2) LEVEL	(3) NATIONAL STOCK NUMBER	(4) DESCRIPTION	(5) U/M
1 2	C C	6850-00-105-3084 8305-00-222-2423	CLEANING COMPOUND, FREON TYPE TF CLOTH, CLEANING F24M16 (H8035)	16 OZ. YARD

By Order of the Secretary of the Army:

E.C. MEYER
General, United States Army
Chief of Staff

Official:

J.C. PENNINGTON
Major General, United States Army
The Adjutant General

DISTRIBUTION:

Active Army:

USAINSCOM (2)
COE (1)
TSG (1)
USAARENBD (1)
DARCOM (1)
TRADOC (2)
OS Maj Comd (4)
TECOM (2)
USACC (4)
MDW (1)
Armies (2)
Corps (2)
Svc Colleges (1)
USASIGS (5)
USAADS (2)
USAFAS (2)
USAARMS (2)
USAIS (2)
USAES (2)
USAICS (3)

MAAG (1)
USARMIS (1)
USAERDAA (1)
USAERDAW (1)
HISA (Ft Monmouth) (21)
Ft Gordon (10)
Ft Huachuca (10)
Ft Carson (5)
Ft Gillem (10)
Ft Richardson (CERCOM Ofc) (2)
Army Dep (1) except
LBAD (14)
SAAD (30)
TOAD (14)
SHAD (3)
USA Dep (1)
Sig Sec USA Dep (1)
Units org under fol TOE:
29-207 (2)
29-610 (2)

NG: None

USAR: None

For explanation of abbreviations used see AR 310-50.

RECOMMENDED CHANGES TO EQUIPMENT TECHNICAL PUBLICATIONS

 <div style="border: 1px solid black; border-radius: 15px; padding: 5px; display: inline-block; margin-left: 20px;"> <p style="margin: 0;"><i>THEN...JOT DOWN THE DOPE ABOUT IT ON THIS FORM. CAREFULLY TEAR IT OUT, FOLD IT AND DROP IT IN THE MAIL.</i></p> </div>		SOMETHING WRONG WITH PUBLICATION	
		FROM: (PRINT YOUR UNIT'S COMPLETE ADDRESS)	
PUBLICATION NUMBER		DATE SENT	
PUBLICATION DATE		PUBLICATION TITLE	
BE EXACT PIN-POINT WHERE IT IS			
PAGE NO.	PARA- GRAPH	FIGURE NO.	TABLE NO.
<div style="border: 1px solid black; height: 400px; margin-top: 10px;"> <p style="text-align: center; font-weight: bold; margin-top: 10px;">IN THIS SPACE, TELL WHAT IS WRONG AND WHAT SHOULD BE DONE ABOUT IT.</p> </div>			
PRINTED NAME, GRADE OR TITLE AND TELEPHONE NUMBER			SIGN HERE

DA FORM 1 JUL 79 **2028-2**

PREVIOUS EDITIONS ARE OBSOLETE.

P.S.--IF YOUR OUTFIT WANTS TO KNOW ABOUT YOUR RECOMMENDATION MAKE A CARBON COPY OF THIS AND GIVE IT TO YOUR HEADQUARTERS.

The Metric System and Equivalents

Linear Measure

1 centimeter = 10 millimeters = .39 inch
 1 decimeter = 10 centimeters = 3.94 inches
 1 meter = 10 decimeters = 39.37 inches
 1 dekameter = 10 meters = 32.8 feet
 1 hectometer = 10 dekameters = 328.08 feet
 1 kilometer = 10 hectometers = 3,280.8 feet

Weights

1 centigram = 10 milligrams = .15 grain
 1 decigram = 10 centigrams = 1.54 grains
 1 gram = 10 decigrams = .035 ounce
 1 decagram = 10 grams = .35 ounce
 1 hectogram = 10 decagrams = 3.52 ounces
 1 kilogram = 10 hectograms = 2.2 pounds
 1 quintal = 100 kilograms = 220.46 pounds
 1 metric ton = 10 quintals = 1.1 short tons

Liquid Measure

1 centiliter = 10 milliliters = .34 fl. ounce
 1 deciliter = 10 centiliters = 3.38 fl. ounces
 1 liter = 10 deciliters = 33.81 fl. ounces
 1 dekaliter = 10 liters = 2.64 gallons
 1 hectoliter = 10 dekaliters = 26.42 gallons
 1 kiloliter = 10 hectoliters = 264.18 gallons

Square Measure

1 sq. centimeter = 100 sq. millimeters = .155 sq. inch
 1 sq. decimeter = 100 sq. centimeters = 15.5 sq. inches
 1 sq. meter (centare) = 100 sq. decimeters = 10.76 sq. feet
 1 sq. dekameter (are) = 100 sq. meters = 1,076.4 sq. feet
 1 sq. hectometer (hectare) = 100 sq. dekameters = 2.47 acres
 1 sq. kilometer = 100 sq. hectometers = .386 sq. mile

Cubic Measure

1 cu. centimeter = 1000 cu. millimeters = .06 cu. inch
 1 cu. decimeter = 1000 cu. centimeters = 61.02 cu. inches
 1 cu. meter = 1000 cu. decimeters = 35.31 cu. feet

Approximate Conversion Factors

<i>To change</i>	<i>To</i>	<i>Multiply by</i>	<i>To change</i>	<i>To</i>	<i>Multiply by</i>
inches	centimeters	2.540	ounce-inches	Newton-meters	.007062
feet	meters	.305	centimeters	inches	.394
yards	meters	.914	meters	feet	3.280
miles	kilometers	1.609	meters	yards	1.094
square inches	square centimeters	6.451	kilometers	miles	.621
square feet	square meters	.093	square centimeters	square inches	.155
square yards	square meters	.836	square meters	square feet	10.764
square miles	square kilometers	2.590	square meters	square yards	1.196
acres	square hectometers	.405	square kilometers	square miles	.386
cubic feet	cubic meters	.028	square hectometers	acres	2.471
cubic yards	cubic meters	.765	cubic meters	cubic feet	35.315
fluid ounces	milliliters	29.573	cubic meters	cubic yards	1.308
pints	liters	.473	milliliters	fluid ounces	.034
quarts	liters	.946	liters	pints	2.113
gallons	liters	3.785	liters	quarts	1.057
ounces	grams	28.349	liters	gallons	.264
pounds	kilograms	.454	grams	ounces	.035
short tons	metric tons	.907	kilograms	pounds	2.205
pound-feet	Newton-meters	1.356	metric tons	short tons	1.102
pound-inches	Newton-meters	.11296			

Temperature (Exact)

°F	Fahrenheit temperature	5/9 (after subtracting 32)	Celsius temperature	°C
----	---------------------------	-------------------------------	------------------------	----

PIN: 042842-000